



“Branket” Design as a Safe Deposit Box Security System using Arduino-Based Tap Sensor

**Arsha Raulnadi Trikusuma, Mona Rizqa, Dhimas Aria Wardhana,
Noora Qotrun Nada***

Faculty of Engineering and Informatics, Universitas PGRI Semarang, Jl. Sidodadi-Timur No.24 Semarang, Central Java 50232, Indonesia

*noora@upgris.ac.id

Abstract. Safe is a safe place to store valuables or documents. Because they are usually made of strong and hard materials, a safe is a place to store valuables and important documents in the event of a natural disaster or fire. In addition, the safe is also equipped with a locking system so that it can also be used to secure valuables or documents from theft. Usually, safes are used by agencies or companies and the general public who have valuable items or documents. Safe security systems that have been used generally use either a manual lock, a rotary lock, or a digital lock. There are several security system developments in the safe, including using a microcontroller-based password and fingerprint code, a fingerprint sensor and an Arduino UNO-based RF remote control, using a microcontroller via SMS and FSK facilities, and other developments in the safe security system. “Branket” (Tap Safe) is a safe with a smart lock system using a knock pattern. The bracket is composed of several electronic components, mainly a microcontroller, a solenoid lock, and a piezoelectric knock sensor. The workflow for using the bracket begins by pressing the power button to turn on the bracket. Then the user sticks his hand into the small space to store or opens the safe by tapping the sensor according to the pattern. Increased security on the bank account includes a locking system with a secret knock pattern, easy to remember by the owner, faster opening of the safe, and the process of opening the safe is difficult for others to know. It is hoped that “branket” will become a new innovation in a unique locking system that still has a high level of security.

Keywords: safes, arduino, knock sensor, smart lock system

(Received 2021-04-30, Accepted 2021-04-30, Available Online by 2021-04-30)

1. Introduction

Safes are one of the most secure storage of valuables or documents [1]. Because it is usually made of strong and hard materials, the safe becomes a place to store valuables and important documents in case of natural disasters or fires [2]. In addition, the safe is also equipped with a locking system so that it can

also be used to secure valuables or documents from theft. Although there are already banks that are also considered safe enough to store money, or the option of digitizing documents, but safes are still used today [3]. This is because safes have advantages such as not having to spend money storage administration fees such as in banks, as well as maintaining the originality of a document to avoid manipulation of documents in digital form. Usually, safes are used by agencies or companies or the general public who have valuable goods or documents [4].

Safes are a convenient storage area but have a high risk of being broken into, so sophisticated security is needed in accordance with technological advances [5]. Safe security systems that have been used generally use locks either with manual locks, rotary locks, or digital locks. The use of keys is already applied as a common security method, but obstacles that occur often find difficulty in opening them. Because the method is arguably still manual and makes it difficult for the user as the need for pull on the lock lever [6]. However, there are several developments in security systems in safes, among others, using password codes, and fingerprints based on microcontrollers, fingerprint sensors and RF control remotes based on Arduino UNO, using microcontrollers through SMS and FSK facilities, and other developments in safe security systems [7].

Along with the development of technology, there is a smart door lock system with a tap pattern [8]. But this system is still reserved for doors or cabinets only. In fact, safes are storage areas that require a secure and unique locking system [9]. So, the tap pattern can also be applied to safes that require security. Knock patterns are a unique innovation but still put forward the security aspect of the safe, where the knock pattern is easy to remember by the owner, the opening of the safe is faster, and has a fairly high confidentiality [10]. So, the process of opening the safe is difficult for others to know. In addition, the tap pattern is also felt faster and more effective than the digital locking system and pins that require longer opening time, as well as fingerprints that need to register each fingerprint [11]. Therefore, “branket” design appeared as a safe with security system using Arduino-based tapping pattern. “Branket” products are expected to be a new innovation in the locking system in a unique safe but still has a high level of security.

2. Introduction

The method used in the writing of this scientific article is by the method of literature studies. According to, research with literature studies is a study that is the same preparation as other research but the source and method of data collection by retrieving data in libraries, reading, recording, and processing research materials [12]. The selection of such methods is based on the purpose of the research to be conducted. This research was conducted to design and develop an application that requires a strong legal basis and theory. Because in the absence of a solid legal and theoretical basis, the application cannot be designed and further developed [13].

The method of literature study uses several steps in its writing. The steps in writing a conceptual article start from extracting information from reliable sources related to what will be discussed. Then all the information that has been obtained is reviewed and analyzed objectively and in accordance with scientific rules [14]. Meanwhile, the necessary literature in the writing of this scientific article, among others, concerning the prevailing laws and regulations in Indonesia, the nature of public policy and democracy, as well as the implementation of the design and design of an application system [15]. The details of the methods or steps used in this scientific article can be described in Table 1.

Table 1. Details of scientific article writing methods

No.	Stages	Description	Method
1.	Literature Study	Collecting various literature related to “Branket” products ranging from the components used includes specifications and uses, and how the system will be implemented.	Discussion

No.	Stages	Description	Method
2.	Analysis product needs	Analyzing the needs of “Branket” components and product features and analyze the suitability of the function of components to be used in “Branket” products.	Discussion
3.	Assembly prototype	Assembling prototype components of “Branket” products in a test board (breadboard) according to the design.	Practice
4.	Testing prototype	Testing the prototype “Branket” product whether it is in accordance with the expected or not.	Practice
5.	Analysis of prototype test results	Analyzing the prototype test results to determine the shortcomings that exist both from the needs of components and the working system of the components.	Discussion

3. Results and Discussion

3.1. Technical Design

Figure 1 shows technical design and features on “Branket”. At first glance “branket” does have the same shape as other safes. However, there are some features in “branket” that are different from other safes. At the top there is a power button, a reset button, a reset indicator light, a power indicator, a power indicator light, and a small space to enter a tap pattern. The existence of this small space is intended so that the tap pattern cannot be seen or read by others. The interior of this small space contains piezoelectric beat sensors and silencers so that the sensor does not read taps on other parts of the safe. In addition, “branket” is also equipped with a sealed emergency section. The existence of this emergency section is in anticipation of technical problems such as the owner of the safe who forgot the knock pattern. Later only special technicians can unseal it.

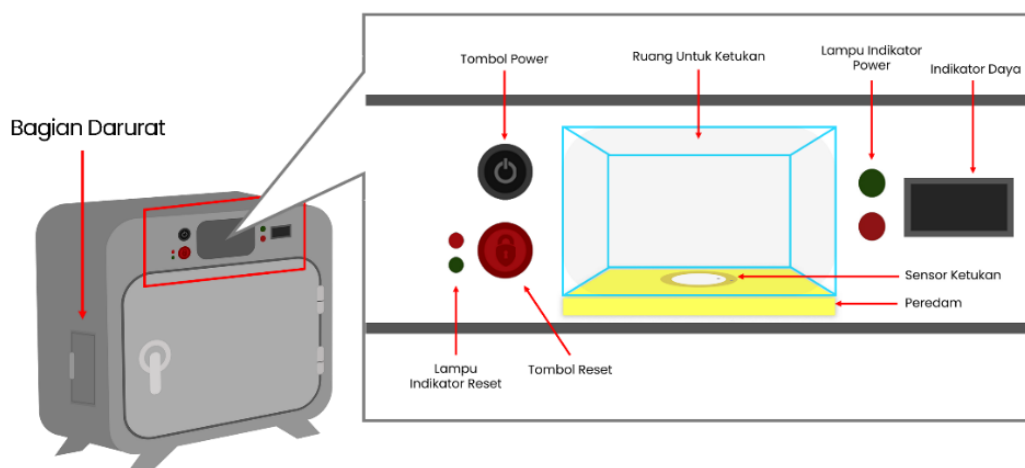

Figure 1. Technical design and features on “Branket”

3.2. Tools and Materials

“Branket” product building materials are divided into two parts: materials for the assembly of prototype series and materials for “branket” products functionally. Materials used for the assembly of the prototype series include Arduino UNO microcontroller, breadboard, piezoelectric beat sensor, 12v solenoid lock, 5v relay, red and yellow/green LED lights, resistors, push-button switches, jumper cables to taste, battery holder case, and two batteries or adapters of 12v each. Then for “branket” products functionally, some raw materials are no longer needed or replaced, among others breadboard, push-button switch, jumper cable, battery holder case, battery, and adapter 12v. Meanwhile, additional raw materials or substitutes include silencers, battery indicator voltmeters, functional buttons, functional cables, as well as a series of power supplies consisting of power supply cables, adapters, PMIC (Power Management Integrated Circuit), and lithium-ion or lithium polymer batteries. Meanwhile, equipment used in the manufacture of “branket” products includes laptops for programming, screws, screwdrivers, solders, etc. Existing equipment is used specifically for the assembly of prototype circuits, assembly circuits on safe bodies, as well as both.

3.3. Creation Process

“Branket” product manufacture is divided into two parts: the assembly of prototype series for testing (Figure 2) and assembly of circuits on the safe body. The assembly process of the prototype circuit for testing is carried out with the help of breadboard. Components assembled on the breadboard include piezoelectric beat sensors, red and yellow/green LED lights, and push-button switches. Then other components are outside the breadboard such as solenoid lock, relay, and Arduino UNO. All of these components are connected to each other by jumper cables and there are also some components that require resistors. The assembly process of the prototype circuit for testing can be divided into 4 parts to make it easier as shown in Figure 3. The first part is the Arduino UNO series with breadboard. The second part is the solenoid, relay, and adapter circuit. The third part is the piezoelectric beat sensor circuit, and the fourth part is a series of knock pattern reset procedures consisting of push-button switches and LED lights.

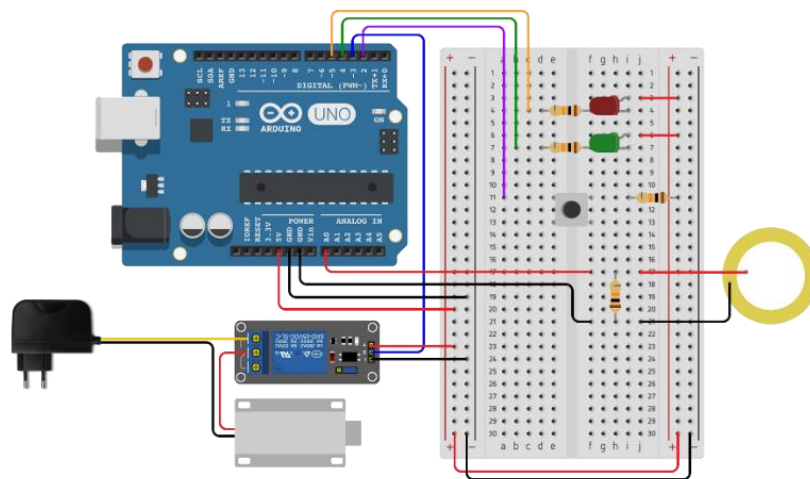

Figure 2. Series of test prototypes

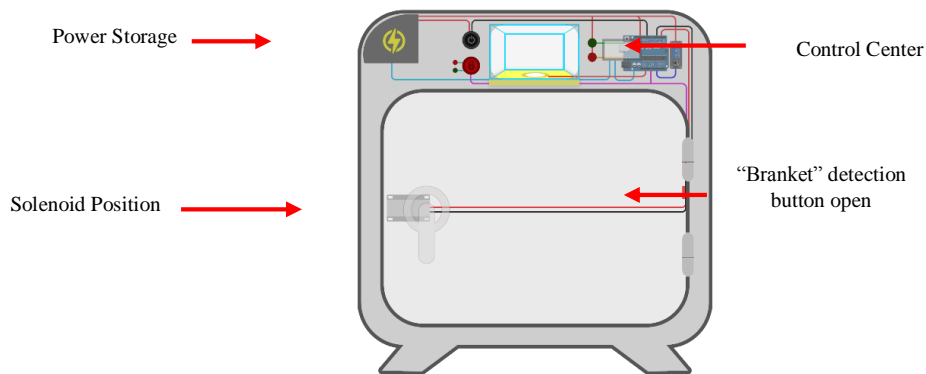

Figure 3. Schematic set of components in “Branket”

Meanwhile, the process of assembling circuits on the safe body is done by selecting components that are still needed, not needed, or replaced with more functional components. Details of component needs in functional products have been explained at the stage of preparation of tools and materials. Most materials or components remain required as the main components of “Branket”. In addition to “Branket” body is made like a typical safe with strong and fire-retardant materials such as titanium which is widely used by safe manufacturers. However, the design of the safe adapts to “Branket”’s features. Component assembly at this stage has also used some additional equipment such as soldering to make the circuit stronger.

3.4. Workflow

“Branket”’s product workflow begins with the testing process on the prototype circuit (Figure 4). The prototype testing process begins by ensuring that the program is uploaded and the components get a power supply, especially for the Arduino and solenoid circuits. Then to save the tap pattern the first time is to press the push-button switch. During pressing, the piezoelectric sensor is tapped with the desired pattern. Push-button switches should not be removed until there is a signal from both LED lights that the pattern has been stored. If the tap pattern is wrong, it will be marked with a red LED light flash. However, if the tap pattern is correct, it will be marked with a green/yellow LED light that lights up and simultaneously the solenoid will open. Overall, “branket” workflows are functionally similar to prototype series workflows in testing. But there are several differentiating procedures. The beat pattern will still be stored in the microcontroller’s memory even if “branket” is not supplied with electricity.

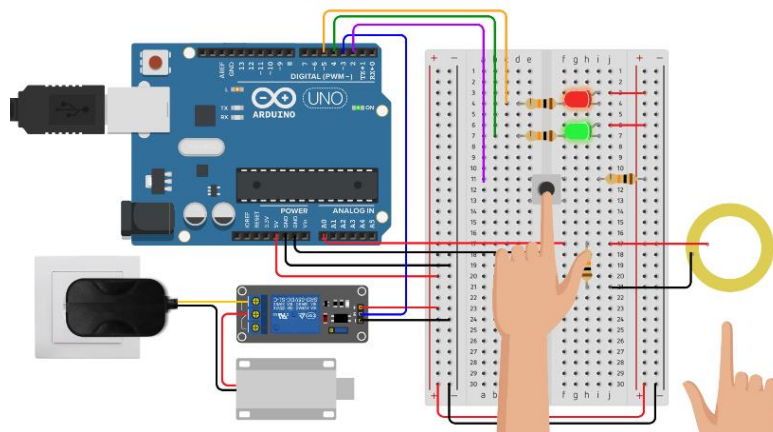

Figure 4. Virtually simulated test pieces

4. Conclusion

Based on the purpose of writing scientific articles and the results of discussions, it can be concluded as follows:

1. “Branket” (Tap Safe) is a safe with a smart lock system using a tap pattern. “Branket” is composed of several electronic components, mainly microcontrollers, solenoid lock, and piezoelectric beat sensors. Before being implemented in the safe, “branket” component sets are first compiled on breadboards for testing. Once tested and able to work as programmed, the circuit can be implemented in the vault.
2. “Branket” usage workflow starts by pressing the power button to turn “branket” on. Then the user puts his hand in a small space to store or open the safe by tapping the sensor according to the pattern. If the pattern is correct, it will be marked with a green LED light that lights up, otherwise if the tap pattern is wrong it will be marked with a red LED light that lights up. The knock pattern reset procedure can only be performed when the vault is open.
3. “Branket” can be a unique and safe innovation in safe locking system. “Branket”'s enhanced security includes a locking system with a secret tap pattern, easy to remember by the owner, faster safe opening, and the process of unlocking the safe is difficult for others to know. “Branket” is expected to be a new innovation in the locking system in a unique safe but still has a high level of security.

References

- [1] D. Antonio, “Rancang Bangun Aplikasi Keamanan Brankas Berbasis Sinar Laser Dengan Mikrokontroler Arduino Nano Dan Uno R3,” *J. Sisfokom (Sistem Inf. dan Komputer)*, vol. 2, no. 2, pp. 12–16, 2013.
- [2] M. Wijaya and T. Susila, “Sistem keamanan brankas secara otomatis berbasis mikrokontroler dengan menggunakan sms serta pin dan rfid,” *Tesla*, vol. 18, no. 2, pp. 139–151, 2016.
- [3] I. N. Sukarma, I. G. S. Widarma, and A. S. Wiguna, “Rancang Bangun Sistem Keamanan Brankas Menggunakan Kombinasi Password dan Sidik Jari Berbasis Mikrokontroler ATMEGA328,” *J. Matrix*, vol. 6, no. 2, pp. 115–118, 2016.
- [4] F. Rabbani, M. K. Resab, and R. Wicaksono, “Sistem Pengamanan Brankas Berbasis GPS Tracking & IoT (Internet of Things),” *J. Autocracy*, vol. 6, no. 1, pp. 36–42, 2019.
- [5] S. Sadi and M. Y. M. Pratama, “Sistem Keamanan Buka Tutup Kunci Brankas Menggunakan Bluetooth HC – 05 Berbasis Arduino Mega 2560,” *J. Tek.*, vol. 6, no. 2, pp. 99–105, 2017.
- [6] F. Yumono, “Sistem Pengamanan Brankas Kantor Perbankan Menggunakan Aktivasi Password Digital Berbasis Mikrokontrol Atmega 8535,” *J. Cendekia*, vol. 11, no. 1, pp. 2–6, 2013.
- [7] D. Haryanto and B. Nugroho, “Sistem Kunci Pintu Rumah Berbasis Arduino UNO Dengan Irama Ketukan,” *Jumantaka*, vol. 3, no. 1, pp. 81–90, 2019.
- [8] H. A. Darwito, A. Saleh, and Y. T. Ichwansyah, “Implementasi Finger Vein Recognition pada Sistem Keamanan Brankas,” in *Seminar Nasional Teknologi Elektro Terapan 2018*, 2018, vol. 02, no. 01, pp. 147–152.
- [9] A. Bazergan and A. Muis, “Rancang Bangun Sistem Pengaman Brankas Berbasis Wireless,” in *Prosiding Seminar Hasil Penelitian (SNP2M)*, 2017, vol. 207, pp. 189–195.
- [10] A. P. Rantelino, R. R. Isnanto, and E. D. Widiyanto, “Sistem Pembukaan Kunci Otomatis Menggunakan Identifikasi Pola Ketukan,” *J. Teknol. dan Sist. Komput.*, vol. 2, no. 4, pp. 281–287, 2014.
- [11] E. Yuliza and T. U. Kalsum, “Alat Keamanan Pintu Brankas Berbasis Sensor Sidik Jari Dan Password Digital Dengan Menggunakan,” *J. Media Infotama*, vol. 11, no. 1, pp. 1–10, 2015.
- [12] A. T. Mahesa, H. Rahmawan, A. Rinharsah, and S. Arifin, “Sistem Keamanan Brankas Berbasis Kartu RFID E-Ktp,” *J. Teknol. dan Manaj. Inform.*, vol. 5, no. 1, pp. 1–9, 2019.
- [13] M. A. Z. Syafiq, A. A. Rafiq, and H. Susanti, “Pengembangan Metode Haar Cascade Classifier

- Pada Pengenalan Mata Untuk Sistem Keamanan Brankas,” in *Seminar Nasional Terapan Riset Inovatif (SENTRINOV) Ke-6*, 2020, vol. 6, no. 1, pp. 895–901.
- [14] S. Lena and Ridwan, “Sistem Keamanan Brankas Menggunakan SMS (Short Message Service) Berbasis Mikrokontroler,” *J. LPKIA*, vol. 1, no. 2, pp. 24–29, 2012.
- [15] M. Ichwan, M. G. Husada, and M. Iqbal Ar Rasyid, “Pembangunan Prototipe Sistem Pengendalian Peralatan Listrik Pada Platform Android,” *J. Inform.*, vol. 4, no. 1, pp. 13–25, 2013.